



Comune di Vinci
Provincia di Firenze

A.11

ABACO DEGLI INFISSI

OGGETTO:

**Ristrutturazione Villa Reghini per Adeguamento Antincendio
- Lotto 1 -**

COMMITTENTE:

Comune di Vinci (FI)

CANTIERE:

Piazza della Pace n.1- 50059 – Comune di Vinci (FI)

Empoli (FI), 2019



Responsabile Unico del Procedimento

Dott. Ing. Massimiliano Poli

DELTA PROJECT
Engineering

Dott. Ing. Massimiliano Poli
(Ordine degli Ingegneri della Provincia di Pisa n.2934/A)
C.F.: PLOMSM81M121046D – P.IVA: 01996080501
Via Cesare Capoquadri n. 12 – 50053 - Empoli (FI)
cell: 346/8832802, uff. e fax: 0571/1723182
email: massimiliano@deltaproject.it
email pec: massimiliano.poli@ingpec.eu

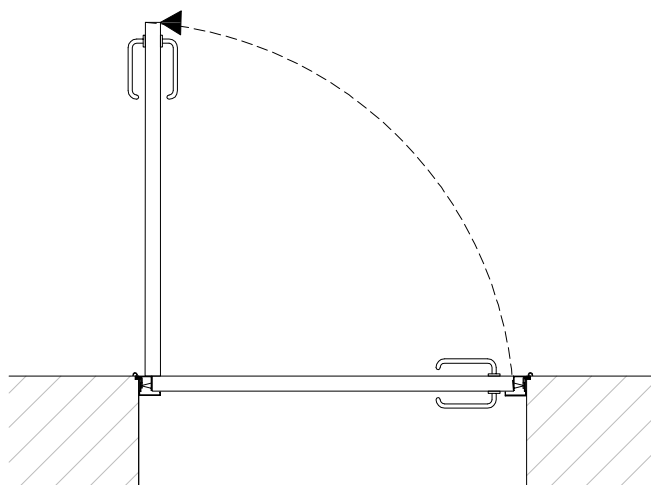
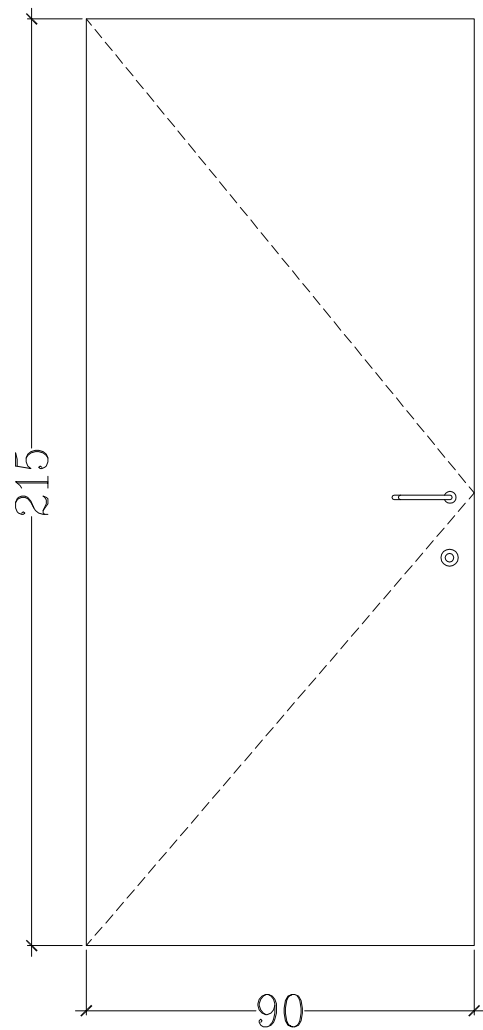

Caratteristiche:

EI 120

Sistema di Apertura:

Battente

Note:

Materiale:

Metallo

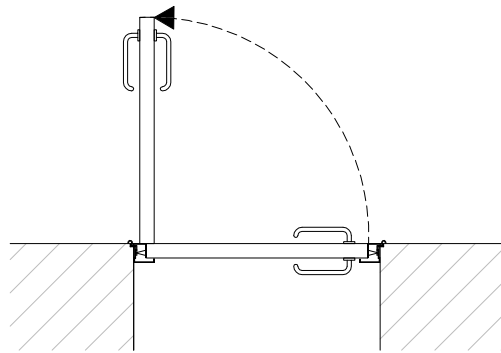
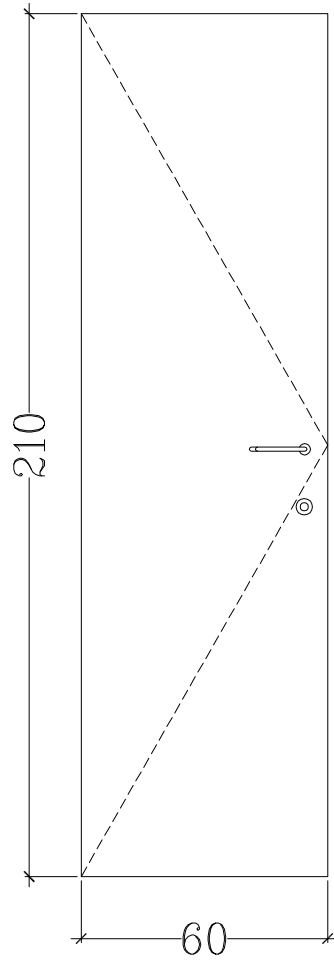

Caratteristiche:

Porta Incombustibile

Sistema di Apertura:

Battente

Note:

Chiusura Automatica

Materiale:

Acciaio verniciato a fuoco con
RAL – def. con DLL e Staz.
Appaltante

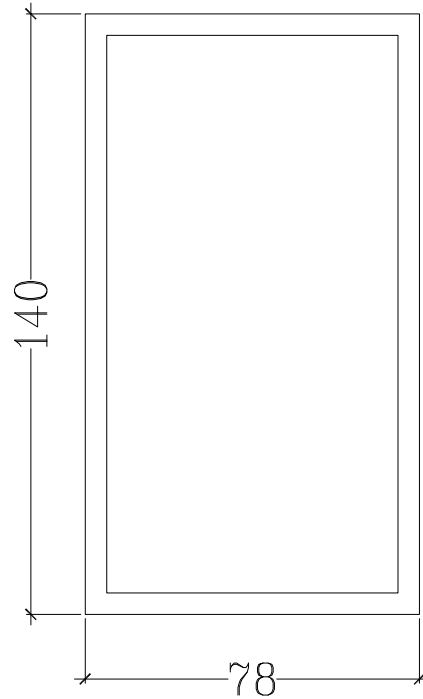

Caratteristiche: Botola per Evacuazione Fumi

Sistema di Apertura: Su asse di rotazione inferiore

Note: Apertura motorizzata

Materiale: Legno e vetro

Pianta Piano Seminterrato

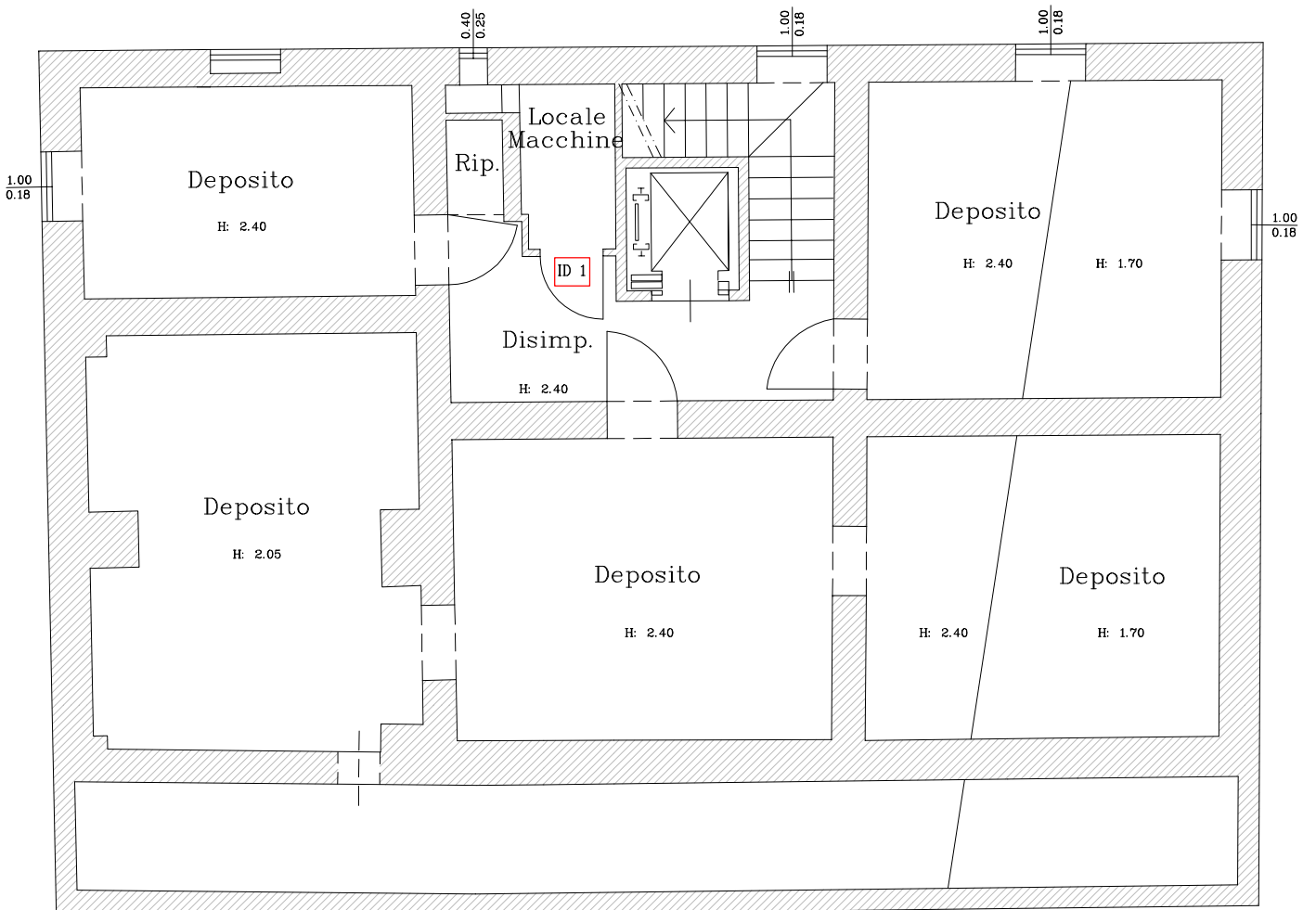

Pianta Piano Terreno

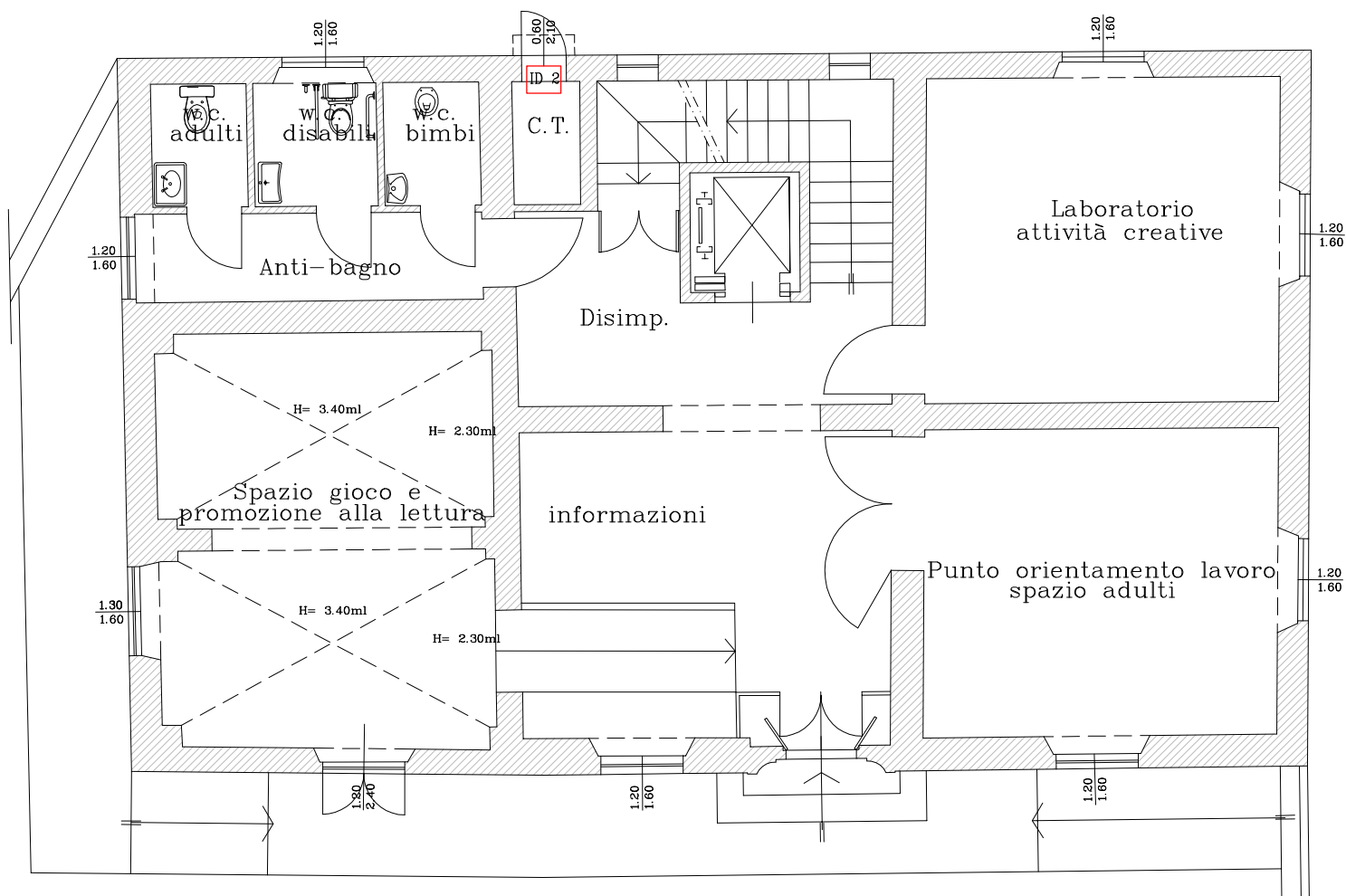

Pianta Piano Primo

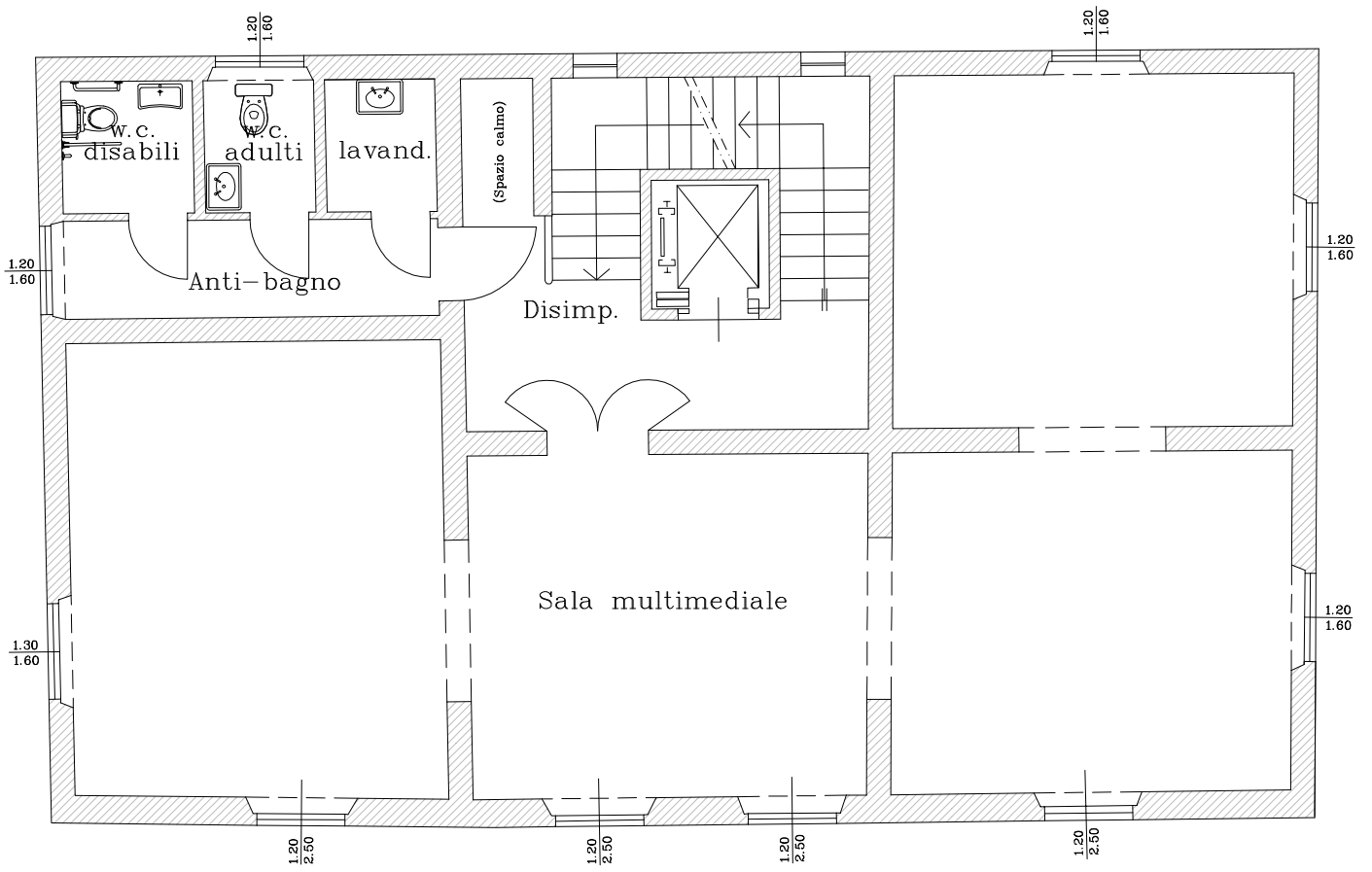

Pianta Piano Secondo

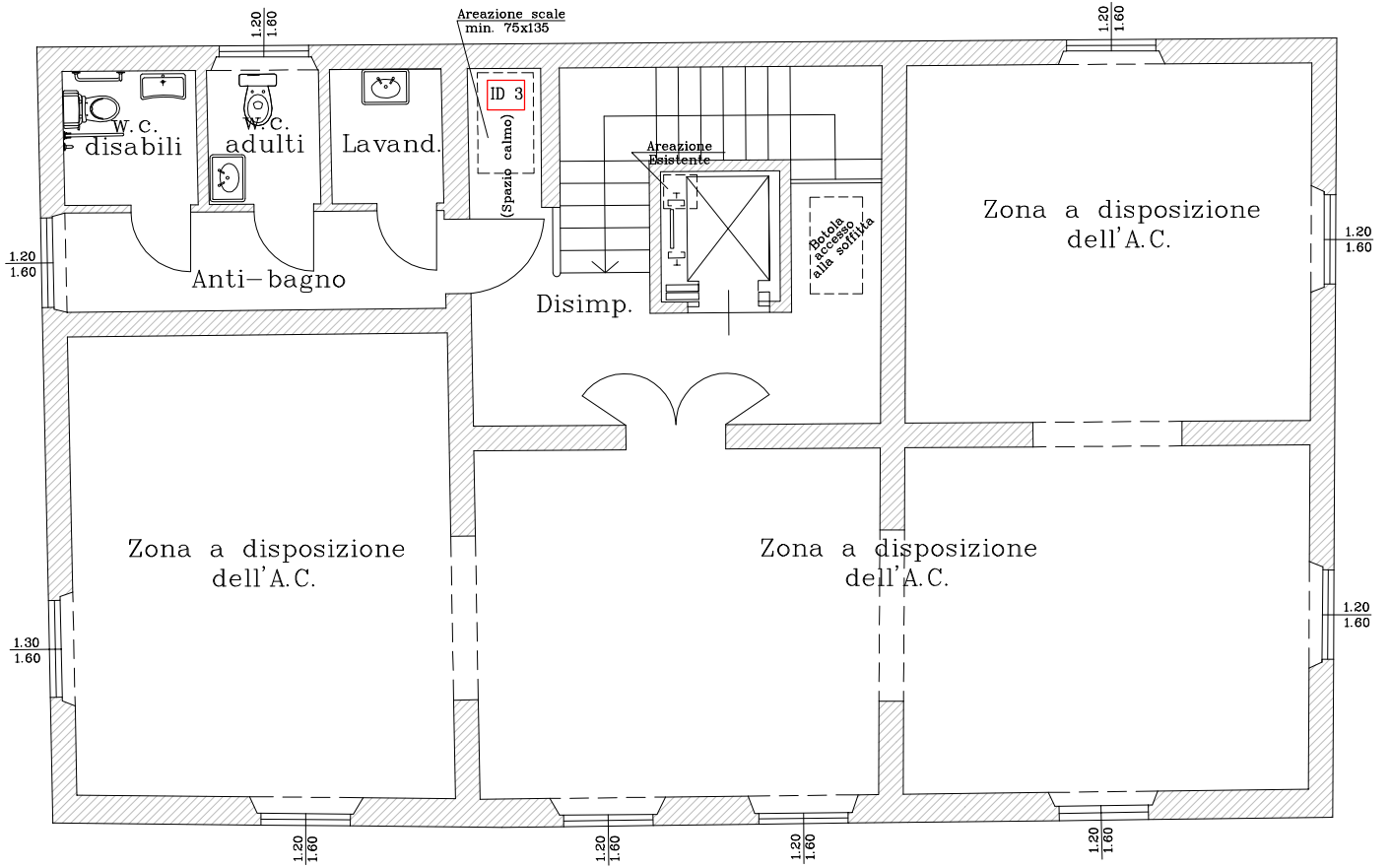

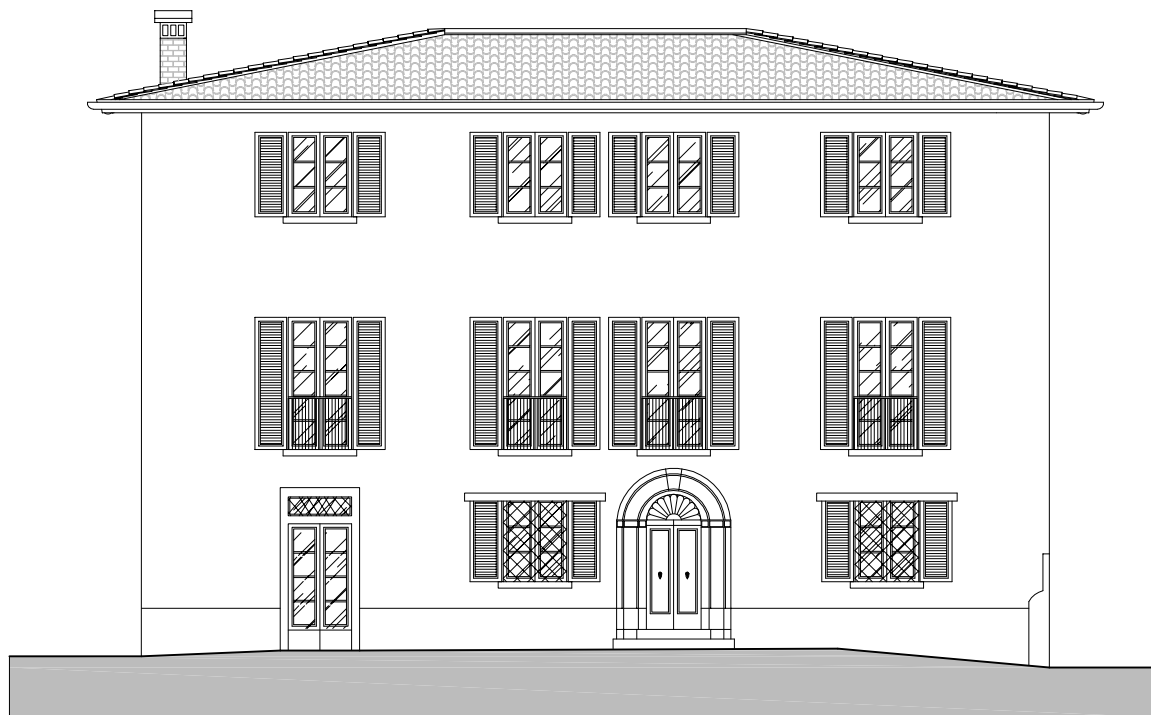

Prospetto Principale

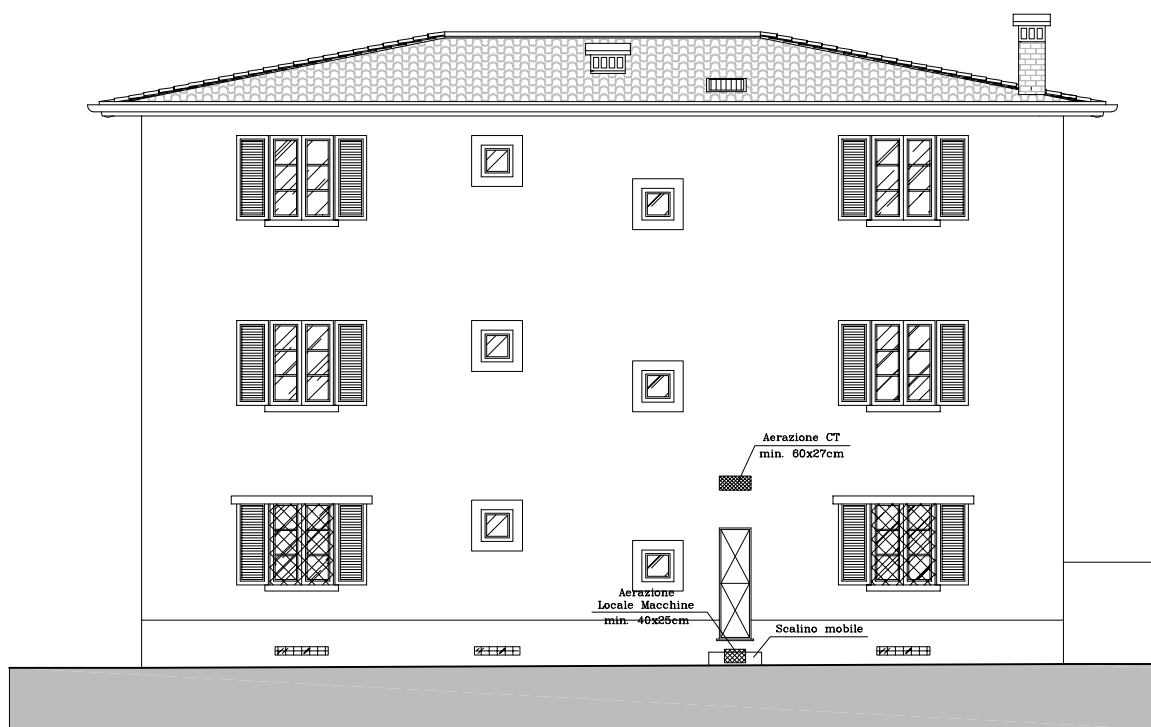

Prospetto Tergale

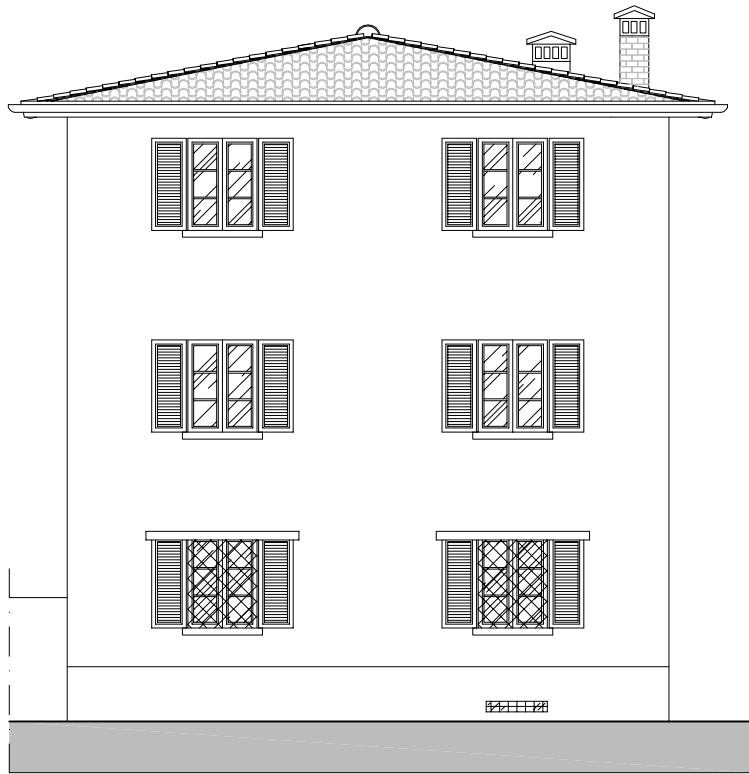

Prospetto Laterale Dx

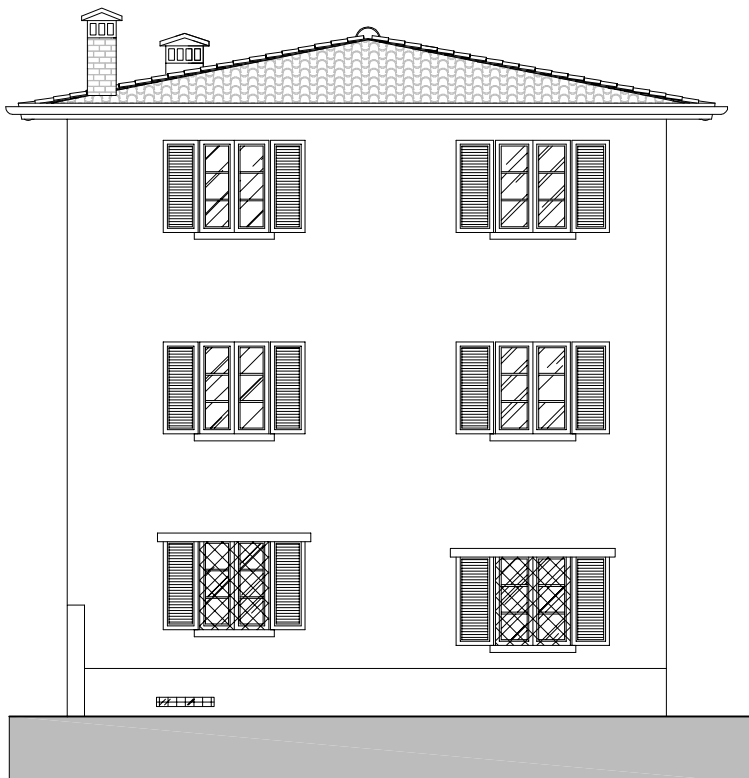

Prospetto Laterale Sx

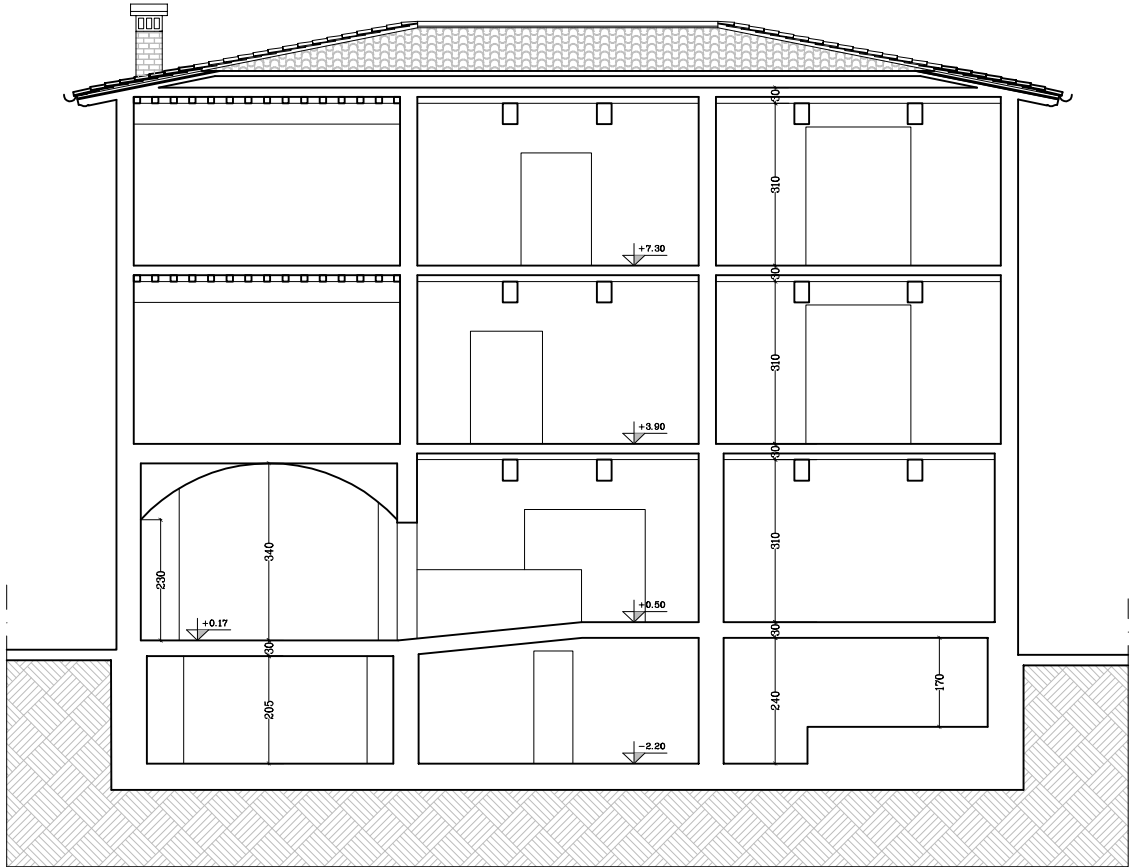

Sezione X - X'

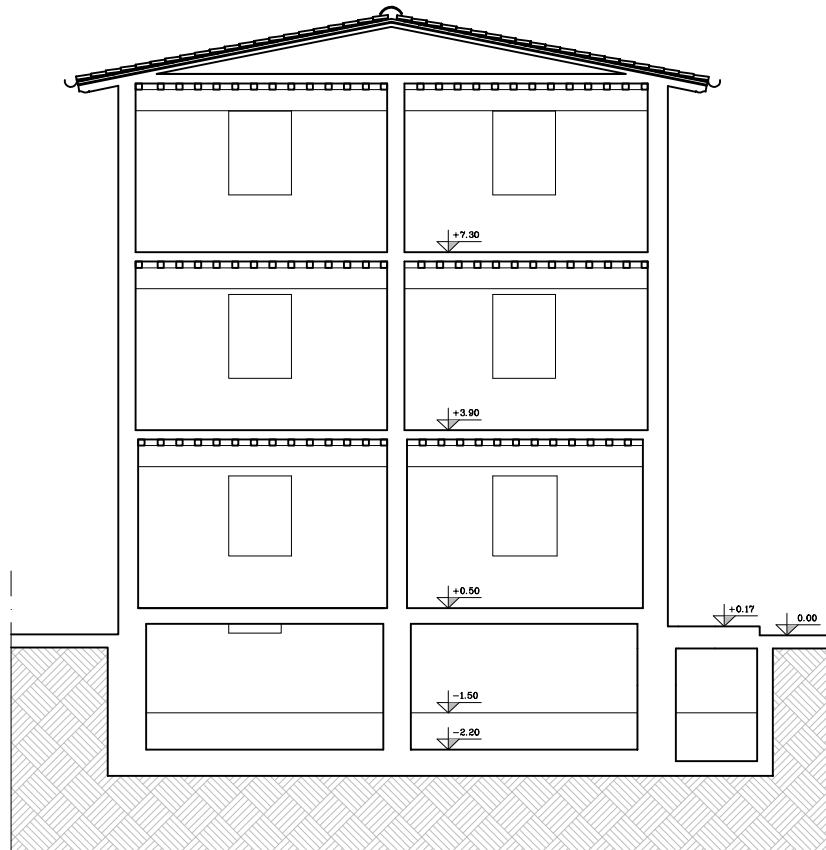

Sezione Y - Y'